



Starling Community

Design Manual

April 2026



DESIGN MANUAL

Table of Contents

Name	Page
Chapter 1: Purpose	4
Chapter 2: Properties and Projects Subject to Design Manual	5
Chapter 3: Relationship to other Documents	6
3.1 Local Land Use Regulations & Building Codes	6
3.2 The Declaration of Protective Covenants & Other Governing Documents for Starling Community	7
Chapter 4: Starling Community Design Review Panel	8
4.1 Function	8
4.2 Membership	8
4.3 Enforcement Powers	8
4.4 Limitation of Responsibilities	9
Chapter 5: Design Review Process	10
5.1 In General	10
5.2 Informal Advice	11
5.3 Form A: Sketch Design Review	12
5.4 Form B: Construction Design Review	13
5.5 Form C: Changes & Modifications	14
5.6 Site Plan Review & Building Permits	14
5.7 Timing of Construction	15
5.8 Inspections	15
5.9 Liability	16
5.10 Successive Owners	16
Chapter 6: Neighborhood Design Patterns	17
6.1 Site	17
(a) Uses, Lot Coverage, Lot Area, Lot Width, Setbacks, Height, Garages, Parking, and Signs	17
(b) Fences & Screens	17
(c) Sidewalks	22
6.2 Building	22
(a) Recommended Energy Star Program	22

(b) Base Element & Foundation	22
(c) Walls & Façades	23
(d) Porches	24
(e) Outdoor Rooms	26
(f) Decks & Patios	27
(g) Windows & Solar Gain	27
(h) Doors	28
(i) Roofs	30
(j) Skylights	31
(k) Roof Mounted Solar Panels	31
(l) Dormers	31
(m) Eaves	31
(n) Chimneys / Roof Vents	33
(o) Lighting	34
(p) Signage	34
6.3 Landscape	35
(a) Plantings	35
(b) Vegetation & Solar Gain	37
(c) Hardscapes	37
(d) Soil Preparation & Drainage	37
(e) Irrigation Systems & Water Use	37
(f) Fertilizing / Pesticides	38
(g) Weed Control	38
(h) Vegetation Removal	38
6.4 Variations from Neighborhood Patterns	39
Chapter 7: Amendments	40
Chapter 8: Definitions	41
Appendix A1: Starling Planned Unit Development (PUD) - Phases 1-4	42
Sec. 1 – Authorized uses	42
Sec. 2 – Lot coverage and floor area	42
Sec. 3 – Lot area and width	42
Sec. 4 – Yards	43
Sec. 5 – Building height	44
Sec. 6 – Residential garages	45
Sec. 7 – Parking	45
Sec. 8 – Signage – Permitted signs for RA-1	45
Sec. 9 – Architectural, additional site and landscape requirements	46

Appendix A2: Deviations from Kalispell Subdivision Regulations	47
Appendix B: Design Review Panel Applications	48
Form A - Sketch Design Review Application	
Form B - Construction Design Review Application	
Form C - Changes Application	

Pursuant to the Declaration of Protective Covenants for Starling Planned Unit Development (“Declaration”), on file with the Flathead County Clerk and Recorder’s Office, the Declarant Starling Development, LLC (“Declarant”), herein adopts the following Starling Community Design Manual (“Design Manual”):¹

Chapter 1 : Purpose

This Design Manual is intended to promote sustainable patterns of development that will encourage people to connect and interact as part of the Starling Community neighborhood and adjacent neighborhoods. The standards within this document provide a framework for design and construction that will allow each project to contribute to the neighborhood and to the long-term goal of complimenting and enhancing the overall Kalispell community. The architectural and landscape elements of site design are integral to the overall desired neighborhood patterns.

Rather than dictate specific design styles, the standards are provided to ensure well-built, compatible, energy-efficient homes with clear order and comprehensive composition. Photographs are included for education, inspiration and reference only and do not imply specific solutions or guarantee regulatory approval.

The goal is to strike a balance between neighborhood harmony and creativity. This document encourages design diversity and contemporary design while providing certain guidance to ensure quality design and longevity in property values. Each project should not simply be an exact copy of another structure. The fact that a given style or feature of building already exists does not guarantee or require that it will be approved for construction again.

Variances to this Design Manual are subject to Section 8.8 of the Declaration and Chapter 6.4 of this Design Manual.

¹ All definitions contained in the Declaration shall have the same meaning when used in the Design Manual.

Chapter **2**: Properties and Projects Subject to Design Manual

Unless specifically excluded in the Declaration, the Design Manual shall inure to, be binding on, and pass with each Lot, parcel, tract or division in Starling Community, and shall apply to the entire Starling Community and all Construction Activity or Improvements performed or placed thereon.

“Construction Activity” and “Improvement” are defined in the Declaration and shall be construed broadly.

Chapter 3: Relationship to other Documents

3.1 Local Land Use Regulations & Building Codes

It is the responsibility of Owner to ensure that all Improvements and Construction Activity strictly comply with applicable laws, ordinances, and rules and regulations in effect at the time such Improvement and Construction Activity are commenced, including without limitation local land use regulations, the International Building Code, other applicable plumbing, electrical, or building codes in effect for the City of Kalispell, and all other laws, rules and regulations of any government or agency under whose jurisdiction the land lies. Local land use regulations can be found online at www.kalispell.com.

Some provisions of this Design Manual may be more restrictive than local land use regulations as part of the overall Starling Planned Unit Development (“PUD”). The more restrictive provisions of the Declaration and Design Manual and any permitted deviations from the local land use regulations shall control.

3.1.1 The Planned Unit Development for Starling Community Phases 1-8 allows the following deviations from the City of Kalispell Zoning Ordinance:

Deviation #	Code Section	Summary of Section
1	27.09.010, 27.09.030	Use: B-1 zoning phase 3, ADU lot restrictions in Phase 2
2	27.09.040 (1)	Lot Area
3	27.09.040(2)	Lot Width
4	27.09.040(3)	Setbacks
5	27.09.040(5)	Permitted Lot Coverage

Deviations #1-5 to the Zoning Ordinance that apply to Starling Community are addressed in Appendix A1

3.1.2 The Planned Unit Development for Starling Community Phases 1-8 allow the following deviations from the Kalispell Subdivision Regulations:

Deviation #	Code Section	Summary of Section
1	28.3.14	Road Sections
2	28.3.14(F)(1)	House Orientation
3	28.3.11(B) and (C)	Alley as Primary Access

Deviations #1-3 to the Kalispell Subdivision Regulations that apply to Starling Community are addressed in Appendix A2

Notwithstanding anything contained in this Design Manual to the contrary, the deviations set forth in 3.1.1 and 3.1.2 may not be varied, amended, modified, or deleted without the express written authorization of the City of Kalispell.

3.2 The Declaration of Protective Covenants and Other Governing Documents for Starling Community

It is the responsibility of Owner to ensure that all Improvements and Construction Activity strictly comply with the Governing Documents for Starling Community, including without limitation the Declaration, the Bylaws, the Design Manual, and Rules and Regulations, and any amendments to the foregoing documents. These documents are available for reference online at www.StarlingCommunity.com.

Chapter **4**: Starling Community Design Review Panel

4.1 Function

The function and purpose of the DRP is to review applications, plans, specifications, materials, samples, and location to determine if the proposed Improvement and Construction Activity conforms to the Governing Documents.

4.2 Membership

4.2.1 Before the Transfer Date, the Declarant may appoint a DRP composed of up to three persons. The persons are not required to be Owners or Members of the Association. The persons may serve on the DRP until he or she resigns or is replaced by the Declarant, whichever occurs first. If no persons are on the DRP, then the Board of Directors shall act as the DRP.

4.2.2 After the Transfer Date, the Board of Directors may appoint a DRP composed of up to three persons; or, if the Board has not appointed any persons to the DRP, the Association may elect one or more persons to the DRP by an Affirmative Vote of a Majority. Any person on the DRP may be removed by an Affirmative Vote of a Majority, and if removed by the Association the Association may elect such member's replacement. The persons are not required to be Owners or Members of the Association. The persons may serve on the DRP until he or she resigns or, if appointed by the Board, is removed by the Board; or, if elected by the Association, is removed by the Association. If no persons are on the DRP, then the Board of Directors shall act as the DRP until such time as they appoint persons to the DRP or the Association elects members to the DRP, whichever occurs first.

4.2.3 The Board of Directors may also engage engineers or other advisors or consultants in the design review process as necessary.

4.3 Enforcement Powers

Should any Owner violate or threaten to violate any part of this Design Manual, the DRP may attempt to work with the Owner to have the Owner cure the violation in a timely manner, and/or refer the violation or threatened violation to the Board of Directors. The Board of Directors may also, and without referral from the DRP, enforce the Design Manual. In addition to any other remedy the Association may have, before the Transfer Date the Board may, in its discretion and at its option, take any or all of the following actions: **(i)** complete the exterior of the Improvement in accord with the approved plans; **(ii)** screen or cover the Improvement; **(iii)** remove the non-complying or incomplete Improvement; **(iv)** retain any or all of the deposit charged by the DRP; **(v)** levy a fine (one time, per diem, weekly, or monthly) in an amount determined by the Board until the construction is in compliance and/or completed; **(vi)** charge the costs incurred to enforce the Governing Documents as a Default Assessment; **(vii)** file and foreclose a lien for the amounts owed to the Association until all amounts owed are fully paid; **(viii)** file a legal action to compel compliance with the

Governing Documents (by injunction or otherwise) and for damages; and **(ix)** exercise any other remedy permitted under the Declaration or at law or equity. After the Transfer, the Board shall have the same enforcement powers but no lawsuit shall be initiated without the Affirmative Vote of a Majority.

4.4 Limitation of Responsibilities

The DRP does not assume responsibility for the following:

- The structural adequacy, capacity, or safety features of the proposed Construction Activity or Improvement.
- Soil erosion, ground water levels, non-compatible or unstable soil conditions.
- Compliance with any or all building codes, safety requirements, and governmental laws, regulations, or ordinances.

Chapter **5**: Design Review Process

5.1 In General

5.1.1 Approval Required to Commence Construction. No Construction Activity or Improvement shall be made, erected, or altered upon any Lot until **(i)** the proper Form(s) is/are submitted, **(ii)** any other information required or requested by the DRP is submitted, **(iii)** all fees and deposits are fully paid, **(iv)** all required Forms are approved in writing by the DRP, and **(v)** any applicable City of Kalispell review or permitting and/or fee payment(s) has been completed. All plans submitted to the City of Kalispell must have Starling Community Design Review Panel Form B stamp of approval.

5.1.2 DRP Discretion. The DRP has complete discretion to approve, conditionally approve, or deny a Form. At the least, the Improvement shall comply with the Declaration and Design Manual; be in harmony with the external design, location, and topography of the surrounding Lots and Starling Community; and not be placed on or under any part of said Lot within an Area of Common Responsibility or easement applicable to the Property, except as approved by the Board of Directors.

5.1.3 Information Required. No Form will be deemed submitted until all information required by the Design Manual and requested by the DRP is provided and all fees and deposits are paid. Incomplete applications may be returned and are subject to a re-submittal fee.

5.1.4 Submitting Forms. Submit 1 Digital Copy of required Form and related materials for each design review to info@starlingcommunity.com.

Also, mail the Form along with payment to the following address:

Starling Community Association, Inc.

2880 Technology Blvd W
Suite 273
Bozeman, Montana 59718

(Checks payable to Starling Community Association, Inc.)

Form A, Form B, and Form C, as may be amended from time to time, may be requested from the DRP or may be downloaded from the website at www.StarlingCommunity.com.

5.1.5 After the Review. Following DRP review, the Owner will be notified as to whether the construction has been approved, conditionally approved or denied.

5.1.6 Withdrawing Application. An Owner may withdraw an application without prejudice, provided the request for withdrawal is made in writing to the DRP before construction has commenced. Owner shall not be entitled to reimbursement of any fees paid with the application.

5.1.7 Variances. Any request for any variance must be made in writing to the DRP. Variance requests are subject to the Declaration, Section 8.8, and Chapter 6.4 of this Design Manual.

5.1.8 Request for Hearing. If an application is conditionally approved or denied, the Owner may request a hearing before the DRP to justify the Owner’s position. The DRP will consider the arguments and facts presented by the Owner and notify the Owner of its decision. Any appeal of the DRP’s decision shall be made pursuant to Section 8.10 of the Declaration.

5.1.9 Event of Inaction. If the DRP does not act on or respond to a Form within forty-five days after receiving the Form, the Form shall be deemed denied. The Owner may resubmit the application, and in this instance no resubmittal fee shall be required.

5.2 Informal Advice

Prior to beginning the design process, it is recommended that Owners and their designated representatives (such as architects, contractors, etc.) contact the DRP to verify their interpretation of the Design Manual. Owners or their designated representatives may, at their option, request a meeting with the DRP to discuss the preliminary plans prior to a full Form A (Sketch Design Review) submittal.

Fee*	Required Documents	Required Submittal Materials (1 digital PDF copy)	Schematic Drawing Checklist
None (except as noted below)	None	Conceptual plans appropriate for informal discussion	N/A

*Note: Additional meetings and/or reviews requested by the Owner and as determined by the DRP to be above and beyond the standard review process are subject to hourly fees in addition to the Design Review fee and must be paid prior to issuance of approval.

5.3 FORM A (Optional) Sketch Design Review

The Sketch Design Review checks designs for general interpretations of the overall Declaration and Design Manual. Form A includes a statement of Acknowledgement. The Lot Owner and/or its designated representative shall take all necessary steps to ensure that they and their contractors, subcontractors, agents, employees, suppliers, and others involved in the development of the Lot are familiar with and agree to abide by the Governing Documents and approved plans.

Note that Form A is **optional**. The Lot Owner may choose to forgo Form A and proceed to Form B if desired.

Fee*	Required Documents (1 digital PDF copy)	Required Submittal Materials (1 digital PDF copy) <i>Half size/scale plots acceptable.</i>	Schematic Drawing Checklist
\$400 for single family design review fee . \$500 for multi-unit design review fee .	Form A (must be signed)	Site Plan (1/16" or 1/8" scale)	North Arrow Property/Setback Lines Easements Sidewalks; Building Footprints; Porches, Stairs, etc; Overhangs (as dashed lines)
		Landscape Plan (1/16" or 1/8" scale)	Schematic Site & Boulevard Landscaping
		Floor Plans (1/8" scale or larger)	Room Use Windows & Doors Overhangs Dimensions Gross SF
		Elevations (1/8" scale or larger)	Porches, balconies Doors, windows Materials specified Overall Height (from average grade) Roof Pitches

*Notes:

- 1) Fee covers Form A & B; if project does not progress past Form A, a \$250 refund will be provided upon request of the Owner.
- 2) Additional meetings and/or reviews requested by the Owner and as determined by the DRP to be above and beyond the standard review process are subject to hourly fees in addition to the Design Review fee and must be paid prior to issuance of approval.
- 3) Incomplete applications may be returned and are subject to a \$100 penalty.
- 4) For fee purposes, "multi-unit" is considered a two-or-more unit townhouse, a duplex, triplex, fourplex, or a single family residence with an ADU (attached or detached). One set of plans for a multi-unit design will be charged a \$500 fee.
- 5) A 50% discount will be applied to duplicate plans with minor changes. Any major plan changes will be considered a new plan.

5.4 Form B (Required) Construction Design Review:

The Construction Design Review checks the construction documents for general compliance with the Governing Documents and verifies that the previous DRP recommendations (if any) have been addressed. Conformity to applicable local regulations and building codes and obtaining appropriate permits is the responsibility of the Owner.

Fee*	Required Documents (1 digital PDF copy)	Required Submittal Materials (1 digital PDF copy) <i>Half size/scale plot acceptable.</i>	Drawing Checklist
\$0 if Form A including \$400/\$500 fee was submitted. \$400/\$500 if Form A was not submitted.	Form B (must be signed)	Site Plan (1/16" or 1/8" scale) All dimensions must be noted.	North Arrow; Property Lines; Setback Lines; Easements; Sidewalk & Street Location; Location, Dimensions, Materials for walks & drives; Building Footprints; Porches, Stairs, etc.; Overhangs (as dashed lines); Fence location & details; Grading Plan; Location and screening of equipment and meters; Limits of construction activity
		Landscape Plan (1/16" or 1/8" scale)	Site landscaping & Boulevard Landscaping
		Floor Plans (1/8" scale or larger) All dimensions must be noted.	Room Use Windows & Doors Overhangs Gross square footage for unit and garage
		Elevations (1/4" scale or larger) All dimensions must be noted.	Porches, balconies Doors, windows Materials specified Overall Height (from average grade) Roof Pitches
		Plan Elevations	Plan elevations with colors notated and color chips.
		Material Samples	As requested by DRP

*Notes:

- 1) Fees paid with Form A (if submitted) cover both Form A & Form B. If no Form A is submitted, Lot Owner will be required to submit the required fee with Form B.
- 2) Form A & Form B may be submitted concurrently.

- 3) Additional meetings and/or reviews requested by the Owner and as determined by the DRP to be above and beyond the standard review process are subject to hourly fees in addition to the Design Review fee and must be paid prior to issuance of approval.
- 4) Incomplete applications may be returned and are subject to a \$100 penalty.
- 5) A 50% discount will be applied to duplicate plans with minor changes. Any major plan changes will be considered a new plan.
- 6) This review does not necessarily require the DRP to confirm that the Construction Activity or Improvement is in compliance with every provision of the Governing Documents. It is the Owner's responsibility to ensure that the Construction Activity or Improvement strictly complies with the Governing Documents.

5.5 Form C Changes & Modifications:

Owners may wish to make improvements or modifications to their Improvements or Lot during the initial construction or at a future date. A change may only be executed after DRP approval of Form C. In addition to any other remedy the Association may have, **any changes or modifications made before Form C is submitted, reviewed, and approved will be subject to an increased fee in an amount to be decided by the Board of Directors.**

Fee*	Required Documents (1 digital PDF copy)	Required Submittal Materials (1 digital PDF copy)	Drawing Checklist
\$150 (for proposed modifications)	Form C	Any relevant drawings related to proposed change(s)	Any details related to the proposed changes.
\$500 (for "after the fact" modifications)			

*Notes:

- 1) Additional meetings and/or reviews requested by the Owner and as determined by the DRP to be above and beyond the standard review process are subject to hourly fees in addition to the Design Review fee and must be paid prior to issuance of approval.
- 2) Incomplete applications may be returned and are subject to a \$100 penalty.

5.6 Site Plan Review & Building Permits

All Construction Activity or Improvements requiring a building permit from the City of Kalispell and some projects may require additional review from the City of Kalispell. Any plans submitted to the City of Kalispell must include Starling Community Design Review Panel stamp and/or letter of approval. This is a requirement of the Association and not the City of Kalispell.

Approval by the DRP does not guarantee approval by the City of Kalispell.

Construction shall not commence without obtaining necessary approvals/permits from the City of Kalispell and the DRP.

5.7 Timing of Construction

An Owner has 1 year from the date of Form B or Form C approval to start construction. If construction of the approved Improvement is not started within 1 year of Form B or Form C approval, new approval must be obtained.

An Owner has 1 year from the date construction commences to complete construction, unless an extension is granted by the DRP. If construction is commenced and is not completed in 1 year or is not completed in strict compliance with what was approved, then in addition to any other remedy the Association may have, the Board of Directors, may take any action that in its judgment is necessary to improve the appearance of the construction or to bring it into compliance with the Declaration, the Design Manual, or the approved plans, including completing the exterior, or removing the uncompleted structure, or any other action. Consideration will be given to remaining landscaping based on seasonal constraints; however, such landscaping must be completed during the beginning of the next planting season. The amount of any expenditure incurred in so doing shall be the Owner's obligation. In addition to any other remedy the Board may have under the Governing Documents or Montana law, the Board may assess a Default Assessment against the Owner and the Owner's Lot for expenses incurred by the Association to bring the Lot into compliance with the Governing Documents.

5.8 Inspections

The Board and/or DRP reserve the right to inspect the Lot at any time to determine if the construction strictly complies with the Declaration, Design Manual, and approved plans. If it is determined that the construction is not in strict compliance with the Declaration, Design Manual, and approved plans, the Board and/or DRP will notify the Owner or successive Owner. The Owner or successive Owner shall have 10 days from the notification to either **(i)** remedy the noncompliance at the Owner or successive Owner's sole costs; **(ii)** submit a work plan delineating a reasonable time frame in which the noncompliance will be remedied (which shall not exceed 30 days from the date of notification without Board or DRP approval, and the Board or DRP may approve up to 45 days if the work plan provides adequate justification for the delay); or **(iii)** submit a Form C (after the fact changes) for review and approval. If the Form C is denied, the Owner or successive Owner shall have 10 days from the date of denial to remedy the noncompliance.

If the noncompliance is not timely remedied, in addition to any other remedy the Association may have, the Board of Directors may, in its sole discretion, remedy the noncompliance. The amount of any expenditure incurred in so doing shall be the Owner's obligation. In addition to any other remedy the Board may have under the Governing Documents or Montana law, the Board may assess a Default Assessment against the Owner and the Owner's Lot for expenses incurred by the Association to bring the Lot into compliance with the Governing Documents.

5.9 Liability

Neither the Starling Community Association, the Declarant, the Board of Directors, the DRP, nor the individual members thereof, may be held liable to any person for any damages for any action taken pursuant to this Design Manual, including but not limited to, damages which may result from review, correction, amendment, changes or rejection of plans and specifications, observations or inspections, the issuance of approvals, or any delays associated with such action on the part of the DRP or Board of Directors.

5.10 Successive Owners

A successive Owner shall be jointly and severally obligated to the Association for any violation of the Declaration, the Design Manual, and the approved plans, for bringing the Construction Activity or Improvement into compliance, and for any lien or Default Assessments which had or may accrue as a result of such violations, without prejudice to such successive Owner's right to recover any such amounts paid from the former Owner.

Chapter 6: Neighborhood Design Patterns

All development must adhere to the neighborhood patterns described in the following sections (Site, Building, and Landscape). Photos are included for reference only.

6.1 Site

The following site design guidelines are intended to provide a framework for site layouts within Starling Community.

(a) Regulations regarding **Uses, Lot Coverage, Lot Area, Lot Width, Setbacks, Height, Garages, Parking, and Signs** are all addressed in Appendix A1: Starling Planned Unit Development Phases 1-4.

(b) Fences & Screens

- Notwithstanding anything stated in the Design Manual, no fencing is allowed in front yards, with the exception of homes facing Stillwater Road. Fencing is not allowed in required street vision triangles.
- When fences are allowed, the following fence types are permitted. See specifications below.
 - A 42” tall fence, only as specified below, is allowed along the woonerf property lines and along an imaginary line setback two-feet inside any property line that borders park or open space. It is also allowed on common private property lines, property lines bordering an alley, side corner property lines facing a street, front property lines of homes facing Stillwater Road setback two feet inside the property line, and returns to the house structure. The two-foot buffer between the fence and the property line bordering park or open space must be planted with a hedge that is well maintained at 42” or less in height.
 - Hedge species may be Lilac, Cranberry Highbush, or a similar species approved by the DRP. Minimum planting size is 24” tall and maximum spacing is 36” on center (OC).

42" Height (3' 6" H) Option A

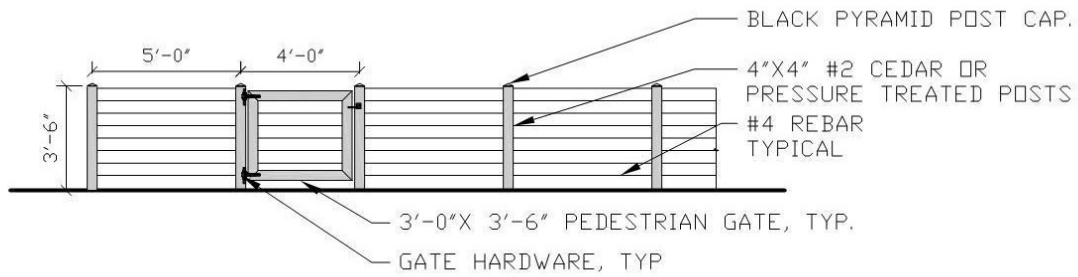

OPTION A

42" Height (3' 6" H) Option B

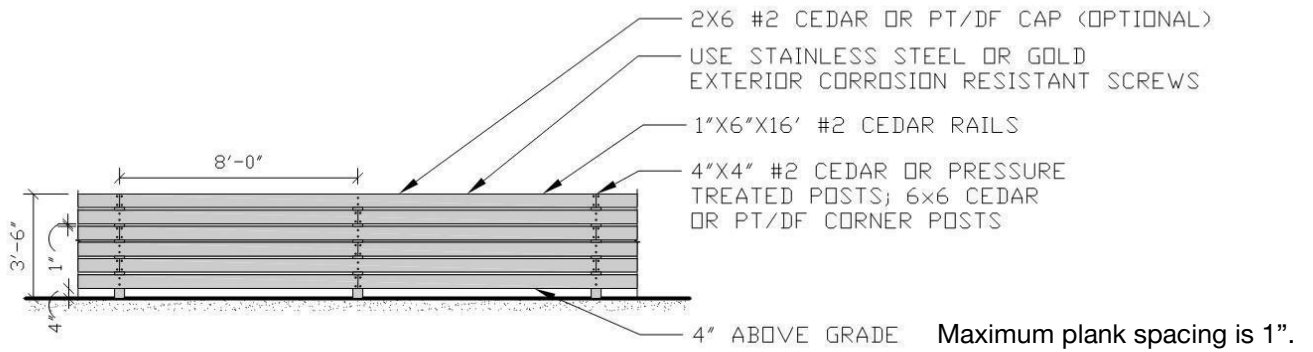

OPTION B

42" Height (3' 6" H) Option C

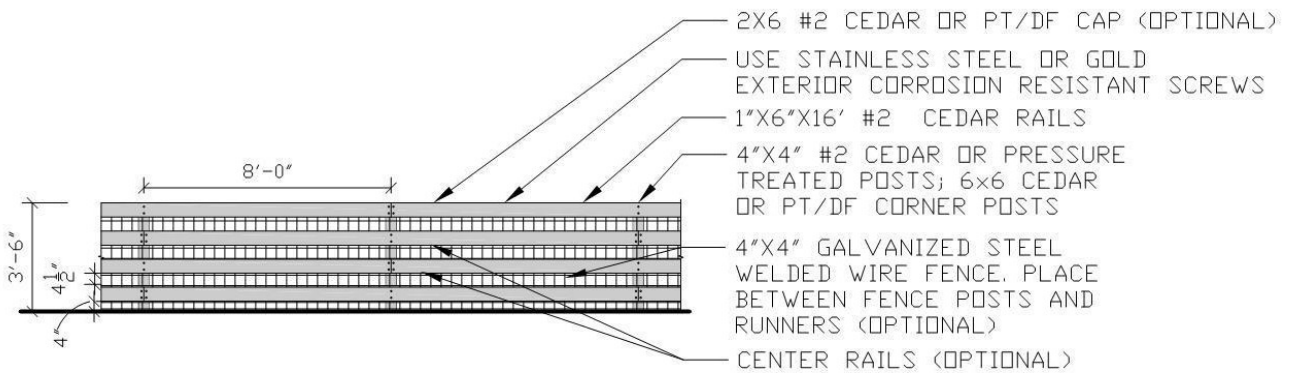

OPTION C

42" Height (3' 6" H) Option D

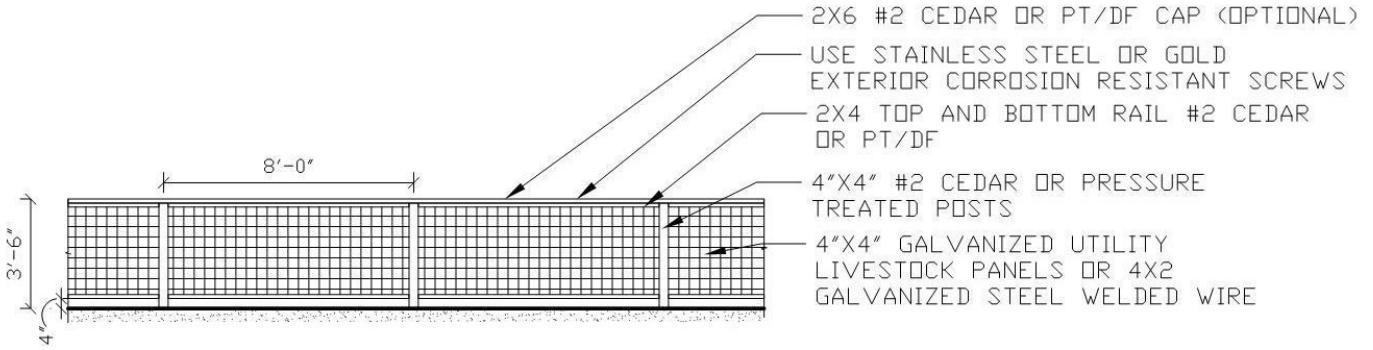

OPTION D

A maximum 4-foot-tall fence, only as specified below, is allowed on common private property lines, returns to the house structure, property lines bordering an alley, and side corner property lines facing a street. When on a side corner, the fence setback from the street must be the same distance as the setback for the house, and the fence may not extend any further towards the street than the rear corner of the house.

4' Height Option A

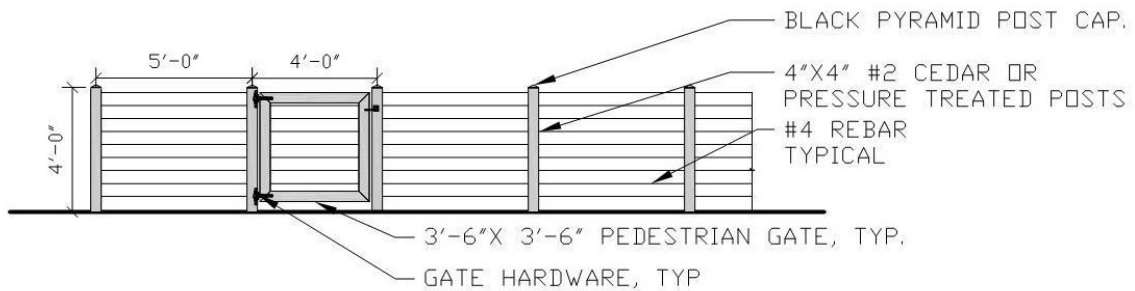

OPTION A

4' Height Option B

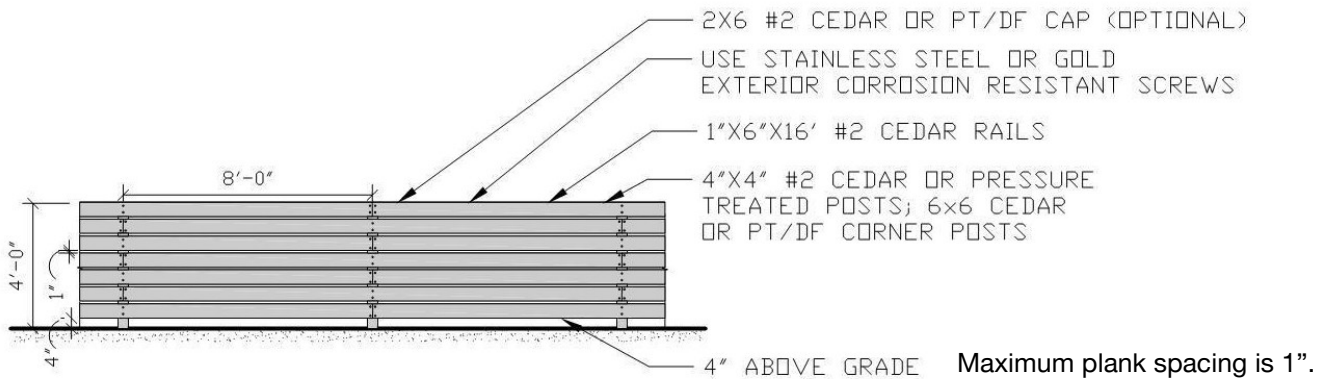

OPTION B

4' Height Option C

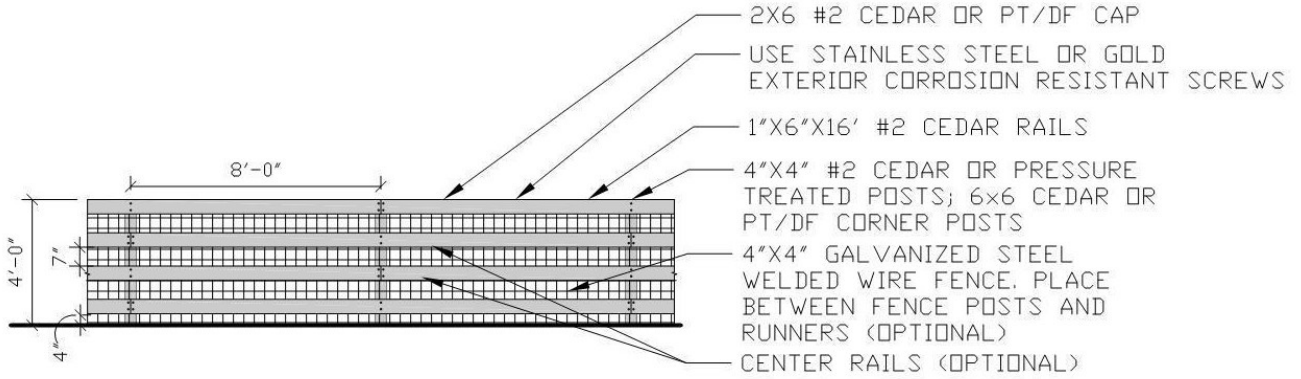

OPTION C

4' Height Option D

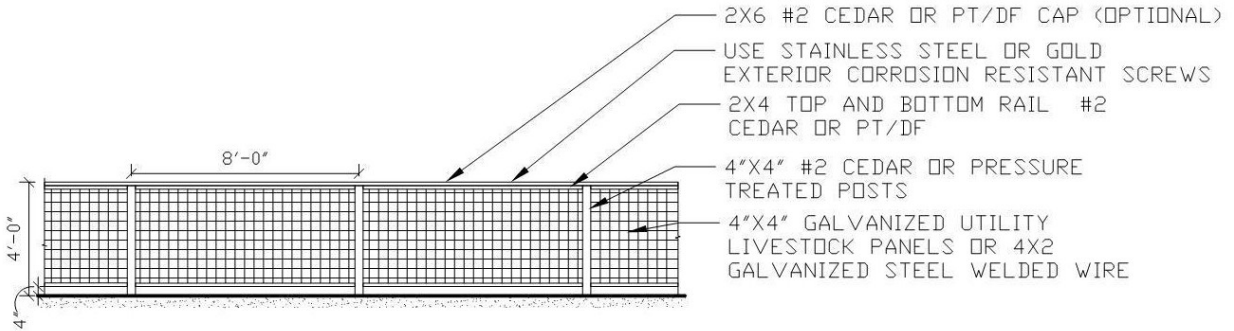

OPTION D

A 6-foot-tall screen fence, only as specified below, is allowed on side corner property lines facing a street. When on a side corner, the fence setback the street must be the same distance as the setback for the house, and the fence may not extend any further towards the street than the rear corner of the house. This type of fence is also allowed on common private property lines, property lines bordering an alley, woonerf property lines and returns to the house structure.

6' Height Option A

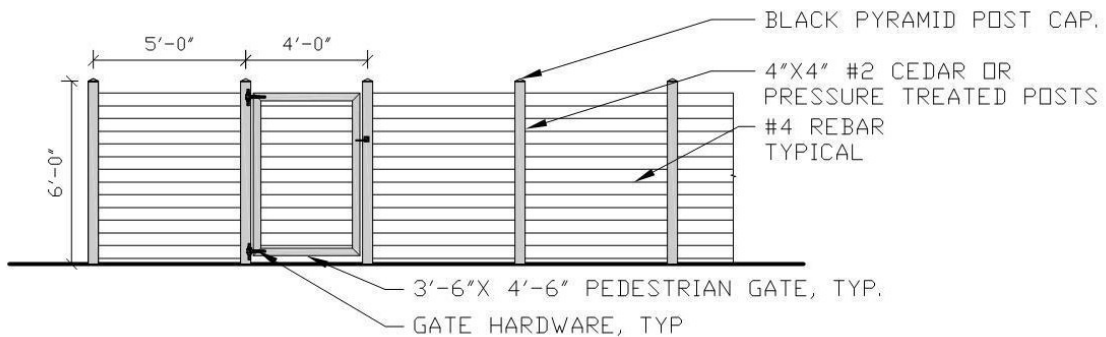

OPTION A

6' Height Option B

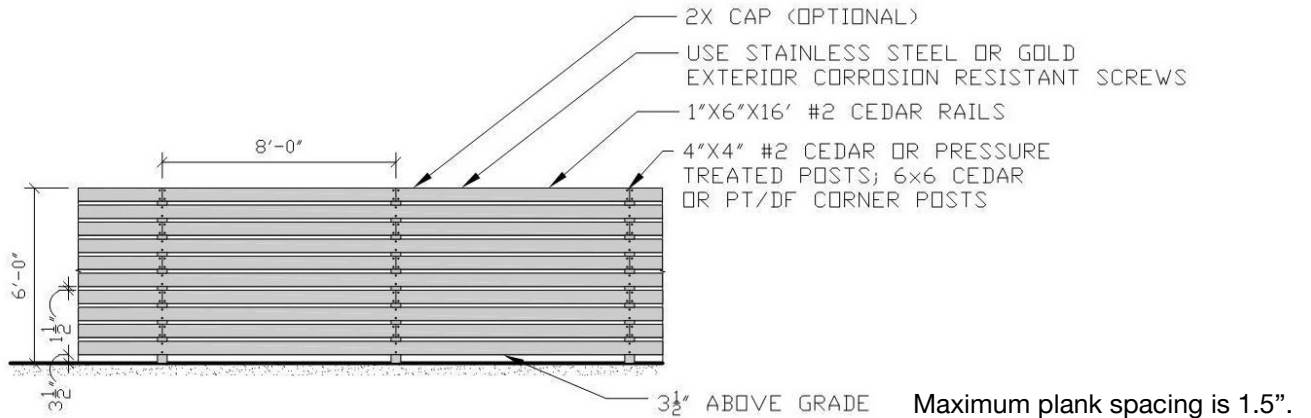

OPTION B

- All fence connections shall be made with stainless steel or gold exterior corrosive resistant screws.
- All fences shall be stained or sealed to protect them from weather and elements and to maintain appearance.
- Screen walls, used for patios or hot tubs, are required to meet all setbacks and must be aesthetically connected to and appear as an extension of a primary residence wall. Outdoor rooms may be designed to include, but shall not be substantially obscured by, screen walls.



- All fence assemblies are required to be maintained for appearance and kept in working order.
- Dog kennels or runs must be attached to a primary or accessory structure, be screened from public streets and adjacent properties, and receive DRP approval for materials and configuration. Chain-link is not permitted. Underground electric fences are encouraged for dogs.

- Utility panel or wire fences must be constructed so that the wire or utility panel is attached and held in place by the fence structure. Staples, alone, are not acceptable to attach the wire to the fencing frame.

(c) Sidewalks

- Any existing City sidewalks in the right-of-way or open spaces that are damaged during construction must be repaired or replaced at the Lot Owner’s expense. Minimum City sidewalk width is 5’.
- Sidewalks on Lots with homes facing local streets are required to cross the boulevard in line with a minimum 4’ wide sidewalk leading to the front porch.

6.2 Building

The following building design guidelines are intended to promote both building diversity and neighborhood compatibility within a developing neighborhood framework.

(a) Recommended Energy Star Program

- Because of its ease and low cost, homes are encouraged to meet or exceed the standards of the “Energy Star” Program. Energy Star homes typically include additional energy-saving features that make them 20–30% more efficient than standard code compliant homes.
- Energy Star Qualified New Homes include:
 - Effective Insulation
 - High-Performance Windows
 - Tight Construction and Ducts
 - Efficient Heating and Cooling Equipment
 - Efficient Products
 - Third-Party Verification
- The specific standards can be found at: http://www.energystar.gov/index.cfm?c=new_homes.hm_index.

(b) Base Element & Foundation

- A base element is required and must be detailed in such a way to visually and structurally connect the building with the ground. It may appear as a platform or terrace upon which the house stands or as a built extension of the ground integrated with the house above. This element may be masonry, concrete, wood or materials matching trim package. Buildings without a base element may be considered based on design merit.



- Foundation walls shall be exposed a maximum of 12-inches above the ground. Exposed foundation walls shall be built of brick, cast concrete, trimmed with horizontal members, or as otherwise approved by DRP. Concrete foundations exposed more than 18-inches above grade must have an architectural finish (texture, pattern and/or color).



(c) Walls & Facades

- All facades of the main building and accessory structures (including garden sheds) shall be made of similar materials and be similarly detailed.
- Primary materials on a façade may change only at a horizontal band or an inside corner. Consideration will be given to changing materials at a visual block such as a fence.
- Varied building massing is encouraged. No exterior wall plane, unless approved otherwise for design merit, shall exceed 35 feet in length without incorporating a minimum 24-inch offset or recess in a significant proportion to the overall plane.
- Building walls shall be clad in smooth cut wood shingles, wood clapboard, barn or reclaimed wood, wood drop siding, traditional wood board and batten, fiber cement siding, architectural metal cladding, brick, or stone. Siding shall be painted or stained; pre-finished siding will be considered based on design merit. Alternative materials, including the use of steel, will be considered based on design merit. Stucco, log, vinyl or aluminum siding is not allowed.



- The color palette of the body of the house shall be as approved by the DRP based on merit. Color schemes must be varied from the two adjacent properties, in each direction and from the properties across the street. Attached dwelling units are exempted from each other. Garish colors are not allowed.

- Exposed exterior wood shall be painted or stained (wood front doors excluded).
- Lap siding shall run horizontally. Maximum lap siding exposure is 7-inch. Combinations of lap exposure will be considered on a case-by-case basis.



- Trim materials should be of high quality and of appropriate visual size. Exterior trim of at least 4-inches is required around windows and doors. Corner caps are acceptable. Variations on trim width and/or exclusion of trim will be considered based on design merit.
- Brick surfaces shall be set predominantly in a horizontal running bond pattern.
- Stonework shall be natural or approved synthetic stone materials. Dry stack, uncoursed settings with minimal exposed mortar are preferred. Stonework shall not be applied to individual wall surfaces to avoid a veneer-like appearance. It shall continue around corners to an inside corner.

(d) Porches

- For yards facing a public street, the eave of a covered front porch of a residential structure must be built within setback line (“build-to” line). Non-covered, slab-on-grade front porches or wheel chair ramps may encroach beyond the setback line by 5’. The width of the porch on the build-to line must occupy a minimum of 30% of the width of the front façade measured along the build-to line. As an alternative to the typical front porch and to provide additional design diversity, narrower but deeper porches that have the same square footage may also be considered. A minimum 6 feet of depth is required.



- Buildings on lots that address two or more streets must address both streets with fronting characteristics as part of the comprehensive composition. Design considerations should include but not be limited to: wrapping front porches, outdoor rooms, variation in wall planes and massing, additional openings and enhanced landscaping. Percentage requirement only apply to one street.
- Porches are also required along woonerfs; however, these porches only have a minimum length or width requirement of 6 feet. The percentage requirement does not apply to porches facing a woonerf.



- Front porches generally must be elevated between 2 and 4 feet above fronting top of curb. Other heights may be considered based on-site conditions and foundation design. Elevation from an alley curb to the garage slab must provide a minimum of 2% positive drainage.
- Porch railings may be opened or closed. If closed, they must be constructed of the same material as the adjacent wall planes.
- Front stoops shall be made of concrete, wood, stone, or brick and must be detailed and integrated into the porch/railing design. Required stair railings must be compatible with the overall stair and porch design.
- Porch supports shall be built of stone, masonry, concrete, or wood. Column base piers shall be no less than 16 x 16-inch square and wood columns shall be no less than 8-inches square. Column groupings must have an outer minimum dimension of 10-inches. Tapered columns may not be smaller than 7 x 7-inches at the top. Columns shall match or be similar in design on all elevations of a structure.
- The balustrade and the space below porches shall be closed and integrated into a closed band and/or landscaped, interrupted as necessary for drainage.

- No exposed stair or deck framing is allowed.



(e) Outdoor Rooms (required on buildings adjacent to open spaces)

- To complement the neighborhood open spaces and courtyards, all lots adjacent to an open space are required to have an “Outdoor Room” facing the open space. This concept is intended to provide a transition from the public green spaces to private indoor spaces. Buildings on lots that address two or more open spaces will only be required to address one open space with an outdoor room. The building, however, will need to address all open spaces. Design considerations should include but not be limited to: wrapping front porches, outdoor rooms, variation in wall planes and massing, additional openings, and enhanced landscaping.



- The minimum size requirement for an outdoor room is 80 square feet with a minimum dimension of 8 feet on both sides.
- Outdoor Rooms typically include covered porches, screened porches, covered patios, or covered decks with integrated landscaping. Partially covered or uncovered patios or decks that are integrated into the overall design and comprehensive composition of the home and landscaping will be considered on design merit.

- Other interpretations of outdoor rooms will be considered based on design merit by the DRP.



(f) Decks & Patios

- Lots that border open space must have decks and patios that face the open space. Non-covered, slab-on-grade patios may not encroach more than 40 percent (feet) into any required side setback. Decks may not encroach beyond the established setback line.

Side Setback	Max Patio Encroachment
3' (side)	1'2"
15' (side corner)	6'

- The space below first floor elevated decks visible from nearby streets or public spaces shall be architecturally detailed and/or landscaped to provide screening.
- Decks, balconies, and terraces shall be designed to enhance the overall architecture of the building by creating variety, layering, and detail on exterior elevations. Covered decks, projecting balconies, and bay windows shall be integrated and composed with the overall building form, rather than placed randomly throughout the building. Terraces shall be used to integrate the building and landscape by creating a transition between the built and natural character of the site.

(g) Windows & Solar Gain



- Windows are encouraged to meet or exceed Energy Star standards as previously stated.
- Openings (including windows and doors) shall not be less than 15% of the wall area, measured on each elevation. Elevation calculations shall include exterior window or door trim.
- Windows shall be wood, wood-clad, fiberglass or vinyl.
- Round, hexagonal and octagonal windows are not permitted.
- Mirrored glass shall not be used.
- Buildings shall have all openings trimmed in wood bands of minimum 4-inches nominal width unless approved based on design merit.
- Bay window projections shall be proportionate to the overall composition and are encouraged to extend to the ground or be trimmed appropriately. Cantilevered bays must be visually carried by structural brackets or a water table trim band. Only cantilevered bays may encroach into a setback.



- False shutters are not permitted.
- Canvas awnings are permitted and shall be square cut without side panels.

(h) Doors

- Exterior doors are encouraged to meet or exceed Energy Star standards as previously stated.
- Front doors shall be solid wood or have a wood appearance. Complimenting wood storm/screen doors are encouraged. High quality synthetic alternatives, such as fiberglass Masonite, may be considered based on detailing and proportions.



- Traditional sliding glass doors may only be used in yards facing open spaces and side yards.
- Garage doors shall be built of wood, steel, or fiberglass.



Garage doors shall be de-emphasized in the elevation of the building. If possible, they should be oriented away from the street. If a lot does not have access to an alley or woonerf and garage doors must face a street, the doors shall be made of a complementary and quality material and have detailing contributing to the elevation composition. Steel garage doors are acceptable.

- To encourage varied massing, garage door wall planes fronting woonerfs must vary a minimum of 24” from adjacent attached wall planes.
- Detached garages and garage doors may front a woonerf if composed with the overall site plan and have significant detailing contributing to the street elevation.



- Other more contemporary and creative approaches to garage doors will be considered based on design merit.



(i) Roofs



- Asphalt composition shingles are permitted, but must be at least 30-year architectural grade.
- Treated wood shingles are permitted.
- Metal roof materials are a permitted but must be designed to protect people and property from significant sliding of snow and ice (not applicable to dormers or similar roof forms that do not drip directly to grade). Metal roofs may be corrugated or standing seam only. Unpainted, galvanized, rusted, brown, grey or rust-red-baked-on finish are all appropriate finishes. Garish colors or shiny materials are not appropriate.
- Natural or synthetic slate roof materials are permitted.
- Flat roofs are permitted on all buildings if integrated with the design. Flat roofs used as balconies on street facades may be enclosed with solid railings.
- Roof plane continuous length dimensions shall not exceed 40' for single family and duplex structures and 100' for multifamily structures without a significant break. Minimum break shall be no less than 20% of the length roof plane and extend up the roof plane no less than 30% of the height of the roof.

(j) Skylights

- Skylights shall be flat in profile (no bubbles or domes).



(k) Roof Mounted Solar Panels

- Solar panels are encouraged for all projects.



(l) Dormers

- Dormer width shall be proportionate to the overall composition.



- Shed dormers shall have a pitch of at least 3:12. Hip and gable dormers shall have the same pitch as the main roof volume.

(m) Eaves

- Overhanging roof eave and gable end soffit depths shall be no less than 24-inches unless approved otherwise based on design merit for a more contemporary style or flat roof. Roof overhang depth on accessory structures must match the main building structure.



- Fascia detail must have a minimum dimension of 8-inches nominal unless otherwise approved for design merit. Two-piece fascia detailing is required. Wood (including Miratec and similar products as determined by the Design Review Committee) is the only acceptable material. Vinyl or metal fascia material is not permitted. As an alternative, exposed rafter tails and entry accents are encouraged if appropriate for the architectural style.



- Soffits shall be wood or metal (including Hardiboard products). Vinyl soffits are not permitted.
- Boxed soffits are allowed when integrated into a suitable architectural style and overall detailing.



- Enclosed soffits are acceptable on more contemporary styles.



- Gutters shall be metal, and of a color and finish that blends with the finish color scheme. Gutters shall be half-round or rectangular and downspouts shall be circular or rectangular.

(n) Chimneys / Roof Vents



- Chimneys shall be clad in stone, masonry, siding, steel or some other compatible or complementary material.
- Chimneys shall be at least 30 x 30-inches.
- Prefabricated metal flues shall be concealed within a chimney unless approved otherwise. Chimney caps may extend above the chimney top per building code requirements.
- Roof protrusions, other than chimneys, shall be arranged to minimize street exposure.
- All roof-mounted equipment shall be integrated into overall design and screened.

(o) Lighting

- All exterior residential lighting shall be dark—sky compliant, free of glare, fully shielded, and emit light downward.



All exterior lighting of all lots shall be limited to 800 lumens (12-watt LED bulbs/60-watt incandescent bulbs) and must be full cut-off and shielded bulb of such focus and intensity so as to not cause disturbance of adjacent lots.

- Recessed or can lighting is encouraged for porches and main entrances for softer lighting conditions.



- The following lighting is prohibited: obtrusive flood lighting, mercury vapor or high-pressure sodium lights, metal halide lights, and clear glass or exposed bulb (non-cutoff) fixtures.
- Pathway lighting is permitted. These types of lights may be attached to the home, along walkways near the ground level, or incorporated into fences. Solar powered lighting is strongly encouraged.
- Woonerfs will be lighted with the LED Cree Edge Series Pedestrian Pathway lighting or equivalent. Streets will be lighted with the LED KIM Archetype light fixtures or equivalent.

(p) Signage

- Typical and temporary "For Sale" signs (and other permitted signs per Appendix A1 Signage) shall be allowed during the sale of a lot or home.

- Signage integrated with landscaping may be placed at the main entrances and parks to identify the neighborhood.

6.3 Landscape

The proper use of plant materials adds to a sense of permanence and consistency for a neighborhood while also connecting the built and natural environments. Landscape plans submitted with Form B shall outline hardscape elements, fencing, and planting areas with species and quantities listed. Each Owner will be required to meet minimum landscape specifications for all yard plantings, including lawns, wooneerfs, and boulevards. It is the responsibility of the Owner to contact the appropriate utility companies before digging and installing any landscaping.

(a) Plantings

- All properties are required to landscape yards, including lawns, wooneerfs and boulevards. Except as otherwise stated herein; lawns facing a street must be sod (fescue blend sod is strongly encouraged); lawns facing open space or side yards may be seeded.
- Native, drought tolerant grasses and regional plant materials are encouraged. Lawns should be well maintained, so they thrive and therefore, use fewer resources. Regular fertilizing (see below), aeration, and weekly cutting with a sharp blade are all critical to lawn success. Lawns should be maintained at about 4-inches as keeping lawns slightly long ensures the soil remains shaded, thereby using less water.
- Mulching, composting, efficient irrigation, harvesting water from roofs, sidewalks, driveways and other impervious surfaces are all encouraged.
- “Xeriscaping” or water-conserving, drought-tolerant landscaping is encouraged. A proposal for a Xeriscape landscape plan must be prepared by a landscape professional. United States Environmental Protection Agency (US EPA) has guidelines available at: <http://www.epa.gov/>.



- **Lawns Facing a Street:** At least 1 tree (minimum 2-inch caliper) and 1 appropriately sized planting beds are required for lawns facing a public street. Corner lots are considered to have 2 separate lawns and therefore require a total of 2 trees (minimum 2-inch caliper) and 1 appropriately sized planting beds.



- **Lawns Facing a Woonerf:** At least 1 tree and 1 appropriately sized planting bed are required for lawns facing a woonerf.
- **Lawns Facing Open Spaces:** At least 1 tree (minimum 2-inch diameter caliper) and 1 appropriately sized planting beds are required for any lawn facing an open space.
- Planting beds must be composed with the site and the building elevations and shall have a top layer of mulch or earth tone stone (non-white).



- Maximum height of landscaping in required vehicle vision triangles is 30-inches.
- It is the responsibility of the Owner to contact the appropriate utility companies before digging.
- **Lots adjacent to Boulevards.** Individual Lot Owners shall be responsible for installing irrigation and landscaping in the boulevard area directly adjacent to their Lot prior to sale or occupancy of the Lot, and for the maintenance of the boulevard

area thereafter, including without limitation maintenance and replacement of any trees installed by the Declarant.

- To enhance a public street boulevard where present, at least 1 deciduous tree (minimum 2.25-inch diameter caliper) shall be planted in the boulevard area. Sod or an approved xeriscape plan must also be installed in the boulevard area directly adjacent to the subject Lot. Tree species must be in accordance with City of Kalispell requirements, which can be found at <https://www.kalispell.com/245/urban-Forestry> > Education & Care > Recommended Boulevard Trees. Mineral mulch is not allowed within public street boulevards or City right-of-ways.
- To enhance a woonerf boulevard where present, at least 1 deciduous tree (minimum 2-inch caliper) and 1 appropriately sized planting bed are required where utility conflicts do not exist. Tree species must be in accordance with City of Kalispell requirements, which can be found at <https://www.kalispell.com/245/urban-Forestry> > Education & Care > Recommended Boulevard Trees.
- Maximum height of landscaping in required vehicle vision triangles is 30-inches.

(b) Vegetation & Solar Gain

- Special consideration should be given to areas of sun exposure and shade for the planting of trees and large shrubs. Landscaping should allow southern exposures necessary for a home's solar gain in the winter, or that of the neighbors.

(c) Hardscapes

- Selection of hardscape materials should favor natural materials such as untreated wood, stone, or stamped concrete, while balancing the desire for durability. Pressure treated lumber and railroad ties, although re-used, should be avoided for their toxicity.

(d) Soil Preparation & Drainage

- Investment at the soil level provides huge payoff in reduced water, fertilizer use, and plant vigor. Soils should be of the best quality available and improved with imported compost as feasible, especially in lawn areas. In areas where poor soils are unavoidable, homeowners should focus plant selection on species that thrive in such conditions. Runoff from roofs, and hardscapes, and melting snow, should be considered, and should be harvested for landscape use whenever possible.

(e) Irrigation Systems & Water Use

- Underground irrigation systems can use water efficiently, but they must be designed, installed and operated correctly. They also require regular maintenance.
- Plants with similar water usage, sun and shade requirements and zones with spray heads, rotors or drip systems should be grouped together.

- Plants should be sufficient in number and density to reduce weed growth. A weed mat also inhibits weed growth. Mulch conserves water and shades soil.
- Landscapes do not require as much water during shoulder seasons (May, June, September and October) as in July and August. Watering should be reduced in September and October to prepare vegetation for dormancy. Early morning is the best time (4am-9am) to water because watering at night can encourage fungus and disease to grow. Avoid watering between 9am – 7pm.
- Water only when your turf requires it. If you leave distinct footprints when you step on it or the grass does not spring back, it is time to water. Applying one inch of water (including rainfall) each time you water once per week is enough to keep your lawn green throughout the summer.
- Turf grass should be watered using longer run times (15-20 minutes) but less often. This causes the grass roots to grow deeper thereby needing less water and becoming more drought and weed resistant. Frequent watering of turf grass causes the root base to remain shallow causing the grass to brown easily and it will be more susceptible to drought and weeds.
- When watering trees and shrubs it is not necessary to water the leaves or the trunk. Instead, place a sufficient number of emitters evenly around the tree or shrub halfway between the trunk and the outer canopy.

(f) Fertilizing / Pesticides

- In careful consideration of the lakes and streams, homeowners that border open spaces or parks with surface water (lakes, streams, wetlands) will only be permitted to use non-chemical fertilizers / pesticides in required yard setbacks. Organic fertilizers for lawns are readily available, as are corn based weed suppression substitutes. Non-lawn native and drought tolerant plantings typically require no extra fertilizing at all.

(g) Weed control

- As further specified in the covenants, noxious weeds pose a serious threat to the environment, and property owners should familiarize themselves with, and control them, on their property. Chemical solutions should be balanced with the threat level of the individual species and the possibility for non-chemical alternative treatments. Under no circumstance should noxious weeds be allowed to flourish or go past the flowering stage and into the seed stage. Weed control is required on both developed and vacant lots and will be enforced in accordance with the Covenants.

(h) Vegetation Removal

- No landscaping in the right-of-way, parks, open spaces and common areas may be removed without prior permission from the DRP.

6.4 Variances from Neighborhood Patterns

The DRP encourages unique and creative design that respects the spirit and intent of the Declaration and Design Manual. Any variance shall be requested by the Owner to the DRP in writing. Except as otherwise set forth in Chapter 3, the DRP may, upon application, recommend approval of a variance from the Design Manual, based on design merit.

However, pursuant and subject to Section 8.8 of the Declaration, the Declarant or Board of Directors shall have the power to make the final decision on whether to approve, conditionally approve, or deny a variance, without any liability being incurred or damages being assessed due to any decision of the Declarant or Board of Directors.

Chapter **7** : Amendments

Amendments to Design Manual may only be made as set forth in the Declaration.

Any amendments to the Design Manual will be posted on the Starling Community website.

A submittal shall be processed consistent with the Design Manual in effect 30 days prior to DRP receipt of a complete Form A submittal.

No Improvements that were constructed and approved in accordance with the Design Manual shall be required to be changed because such standards are thereafter amended.

Chapter **8**: Definitions

The words and terms used in this document shall have their customary dictionary definitions unless otherwise specifically defined within the Declaration or this Design Manual.

DATED THIS 9th day of April, 2026.

Declarant:

Starling Development, LLC,
a Montana limited liability company

By: 

Chad Pelley

Its: Manager

Appendix A1

STARLING PLANNED UNIT DEVELOPMENT (PUD) – Phases 1-4

Sec. 1 - Authorized uses. For authorized RA-1 uses in Phases 1-2, see the Declaration, Exhibit D; for authorized RA-1 and B-1 uses in Phase 3, see the Declaration, Exhibit E; for authorized RA-1 uses in Phase 4A, see the Declaration, Exhibit F; and for authorized RA-1 uses in Phase 4B, see the Declaration, Exhibit G.

Sec. 2 - Lot coverage and floor area.

- A. Maximum lot coverage by principal and accessory buildings shall be:
1. Not more than 60 percent of the lot area
- B. There are no FAR (floor area ratio) requirements for Phases 1-4.

Sec. 3 - Lot area and width.

- A. All lots shall have a minimum area as set forth in the table below and are cumulative. These minimums assume a lack of development constraints.

Table of Minimum Lot Areas for Starling Community PUD	Minimum Lot Area (SF)
Single-household dwelling	4,000
Lot area <i>per townhouse</i> (including 2, 3 or 4 attached units townhomes)	2,350
Area required for a detached accessory dwelling unit	5,000

- B. All lots shall have a minimum width as set forth in the table below. These minimums assume a lack of development constraints.

Table of Minimum Lot Widths for Starling Community PUD	Minimum Lot Width
Single-household dwelling (non ADU lots)	40
Accessory dwelling unit (permitted on a single lot with min 100' depth)	50
Townhouses	14

Sec. 4 - Yards

A. Minimum setbacks required are:

1. Single Household Dwelling (Non-ADU lots)
 - a. Front Yard – 15ft
 - b. Side Yard – 3ft
 - c. Rear Yard – 10ft
 - d. Side Corner – 15ft
 - e. Garage to street right-of-way – 20ft
 - f. Garage to alley (for alley loaded lots) – 10ft

2. Accessory Unit Dwelling (no more than 1,000 sq ft in size)
 - a. Front Yard – 15ft
 - b. Side Yard – 3ft
 - c. Rear Yard – 10ft
 - d. Side Corner – 15ft
 - e. Garage to street right-of-way 20ft
 - f. Garage to alley (for alley loaded lots) – 10ft

3. Accessory Structures (400 sq ft and under. Includes gardening sheds)
 - a. Front Yard – Not allowed*
 - b. Side Yard – 3ft
 - c. Rear Yard – 10ft
 - d. Side Corner – 15ft

4. Accessory Structures (greater than 400 sq ft and up to 1,000 sq ft)
 - a. Front Yard – 15ft
 - b. Side Yard – 3ft
 - c. Rear Yard – 10ft
 - d. Side Corner – 15ft

* All accessory structures 400 sq ft and under must be located behind the principal structure. Accessory structures may not exceed more than 1,000 sq ft in size.

B. Yard Encroachments:

1. Lots that border open space must have decks and patios that face the open space. Non-covered, slab-on-grade patios may not extend more than 40 percent feet into any required side setback. Decks may not encroach beyond the established setback line.

Side Setback	Max Patio Encroachment
3' (side)	1'2"
15' (side corner)	6'

2. Non-covered, slab-on-grade porches may encroach up to 5 feet into a 15' front yard setback facing a street or 15' yard facing a Woonerf only if all four of the following conditions are met:
 - a. The encroaching porch must have a length equal to or greater than one-third the length of the building façade or 12 feet, whichever is greater. The remaining portion may be occupied by an integrated façade as defined in this Design Manual:
 - b. The encroaching porch must have a minimum depth of six (6) feet;
 - c. Second or subsequent stories are not allowed to encroach into the 15-foot street or Woonerf facing yard; and
 - d. No stairs are permitted beyond the 10-foot setback.

Sec. 5 - Building height.

Maximum building height for each residential district shall be as follows:

Table of Heights for Starling Community	Height (in feet)
Less than 3:12	34
3:12 or greater but less than 6:12	38
6:12 or greater but less than 9:12	42
Equal to or greater than 9:12	45
Accessory Dwelling Unit (single level only)	18
Accessory Structures (single level only)	18

Sec. 6 - Residential garages.

- A. Attached residential garages facing a street shall not obscure the entrance to the dwelling. Attached garages are required to be clearly subordinate to the dwelling. A subordinate garage **has two or more** of the following characteristics:
 - 1. The principal facade of the dwelling is emphasized with architectural features such as, but not limited to, porches, fenestration treatment, architectural details, height, orientation or gables, so that the non-garage portion of the residence is visually dominant;
 - 2. The facade with the garage vehicle entrance is recessed at least four feet behind the facade of the dwelling containing the main entry; **and/or**
 - 3. The area of the garage vehicle door comprises 30 percent or less of the total square footage, exclusive of any exposed roof areas, of the principal facade of the dwelling. Principal facade shall include all wall areas parallel to the garage door.
- B. Residential garages facing a woonerf are not required to meet the above criteria.

Sec. 7 - Parking

- A. Parking requirements in terms of the number and size of spaces are the same as the most current version of the Kalispell Zoning Ordinance chapter 27.24. ADUs require one additional off-street parking space.
- B. Where a woonerf or alley serves lots, access to garages and off-street parking shall be off the woonerf. In cases where a woonerf is not adjacent to a lot, accesses to garages are permitted to be off the street.
- C. Driveways are encouraged to be shared wherever possible to minimize street cuts and maximize on-street parking options.
- D. All “required” parking spaces must meet the minimum dimensions established in the Kalispell Zoning Ordinance of 9’ wide x 20’ deep.
- E. Parking spaces shall not block sidewalks, woonerfs, driveways, accesses, pedestrian facilities or snow removal/plowing.
- F. The developer will provide parking spaces along the woonerf in several designated locations. Driveways must be located outside of these parking areas.

Sec. 8 - Signage - Permitted Signs for RA-1

- A. The use of signs is regulated according to zoning classifications as specified in the Kalispell Zoning Ordinance 27.22.

- B. Temporary signs for the sale of real estate, construction, special events, political signs, campaign signs, and neighborhood yard or garage sale signs are allowed without obtaining a permit. See 27.22.050 for periods of time allowed for non-permitted signs to remain on the property.
- C. One freestanding sign will be permitted not to exceed 24sf per sign face and no taller than 6ft above natural grade.
- D. Home occupations are limited to one non-illuminated wall sign not to exceed 6sf.
- E. Wall signs, canopy signs, and marquee signs.

Sec. 9 - Architectural, Additional Site and Landscape Requirements

- A. Starling Community Design Manual includes additional site, architectural and landscape requirements that are all subject to review and approval by Starling Community Design Review Panel.

Appendix A2: Deviations from Kalispell Subdivision Regulations

The Planned Unit Development for Starling Phase 1-8 allows the following deviations from the Kalispell Subdivision Regulations:

1. Road Sections 28.3.14 The deviation would allow three alternative road sections: (a) 80 foot urban collector with 16 ft landscape boulevards; (b) 30 foot wide alleys; and (c) the 32ft wide woonerf.
2. House Orientation: Section 28.3.14(F)(1) – This deviation allows homes to face Stillwater Road provided that access is provided only from the alley behind the homes.
3. Alley as Primary Access: Section 28.3.11 (B) and (C) – This deviation allows homes along Stillwater Road to be accessed only from an alley.

Appendix B: Design Review Panel Applications

Form A - Sketch Design Review Application

Form B - Construction Design Review Application

Form C - Changes Application

Sketch Design Review Application - FORM A

Property Information:

Street Address: _____

Owner Information:

Name: _____

Mailing Address: _____

Phone: _____ Email: _____

Architect Information:

Name: _____

Mailing Address: _____

Phone: _____ Email: _____

Builder Information:

Name: _____

Mailing Address: _____

Phone: _____ Email: _____

Landscape Designer Information:

Name: _____

Mailing Address: _____

Phone: _____ Email: _____

Information:

1. Are any variances from Starling Community Design Manual being requested under this application?

- Yes
- No

If yes, please describe the variance:

Sketch Design Review Application - FORM A

2. Submit Digital Plans (PDF) to info@starlingcommunity.com

- Site Plan
- Floor Plans
- Roof Plan
- Elevations
- Landscape Plans

3. Submit Review Fee (Checks payable to Starling Community Association, Inc.)

- \$400 for single family or \$500 for multi-family

Fee covers Form A & B; if project does not progress past Form A, a \$250 refund will be provided upon request of the owner.

Mail to: Starling Community Association, Inc.
 2880 Technology Blvd West
 Suite 273
 Bozeman, MT 59718

Acknowledgement Statement

The Lot Owner acknowledges that he/she has received and read the Declaration, Design Manual, Rules and Regulations, Bylaws, and other governing documents, and all amendments and supplements thereto (“Governing Documents”). The Governing Documents may also be reviewed at any time at www.starlingcommunity.com. The Lot Owner agrees to abide by the Governing Documents.

As stated in both the Declaration and Design Manual, the failure to strictly comply with the Governing Documents in the construction of any Improvement on the Lot may result in the Board taking action against the Lot Owner, including without limitation assessing substantial fines and requiring the Owner to pay all costs to bring the Lot into compliance.

I/We have read this Acknowledgment Statement. Furthermore, I (We) have been given sufficient opportunity to discuss any questions we may have regarding these requirements with a member of the Design Review Panel. My (Our) signatures(s) below is / are evidence of my/our intent to comply with these requirements.

Owner Signature: _____ Date: _____

Printed Name: _____

The Builder/Contractor acknowledges that he/she has received, read, and will abide by the Declaration, Design Manual, and the Builders/Contractors Rules & Regulations.

I/We have read this Acknowledgment Statement. Furthermore, I (We) have been given sufficient opportunity to discuss any questions we may have regarding these requirements with a member of the Design Review Panel. My (Our) signatures(s) below is / are evidence of my/our intent to comply with these requirements.

Builder/Contractor Signature: _____ Date: _____

Printed Name: _____



Construction Design Review Application - FORM B

Property Information:

Street Address: _____

Owner Information:

Name: _____

Mailing Address: _____

Phone: _____ Email: _____

Architect Information:

Name: _____

Mailing Address: _____

Phone: _____ Email: _____

Builder Information:

Name: _____

Mailing Address: _____

Phone: _____ Email: _____

Landscape Designer Information:

Name: _____

Mailing Address: _____

Phone: _____ Email: _____

Information:

1. Are any variances from Starling Community Design Manual being requested under this application?

- Yes
- No

If yes, please describe the variance:

Construction Design Review Application - FORM B

2. Submit Digital Plans (PDF) to info@starlingcommunity.com
- Site/Grading Plan
 - Floor Plans
 - Roof Plan
 - Elevations & Sections
 - Samples & Cut Sheets
 - Exterior Paint Colors (On Labeled Elevations)
 - Selections & Colors of Metal Roofing, Siding, & Wood Siding (On Labeled Elevations)
 - Rendered Elevation
 - Landscape Plan
3. Submit Review Fee (Checks payable to Starling Community Association, Inc.)
- \$400 for single family or \$500 for multi-family

Mail to: Starling Community Association, Inc.
 2880 Technology Blvd West
 Suite 273
 Bozeman, MT 59718

Acknowledgement Statement

The Lot Owner acknowledges that he/she has received and read the Declaration, Design Manual, Rules and Regulations, Bylaws, and other governing documents, and all amendments and supplements thereto ("Governing Documents"). The Governing Documents may also be reviewed at any time at www.starlingcommunity.com. The Lot Owner agrees to abide by the Governing Documents.

As stated in both the Declaration and Design Manual, the failure to strictly comply with the Governing Documents in the construction of any Improvement on the Lot may result in the Board taking action against the Lot Owner, including without limitation assessing substantial fines and requiring the Owner to pay all costs to bring the Lot into compliance.

I/We have read this Acknowledgment Statement. Furthermore, I (We) have been given sufficient opportunity to discuss any questions we may have regarding these requirements with a member of the Design Review Panel. My (Our) signatures(s) below is / are evidence of my/our intent to comply with these requirements.

Owner Signature: _____ Date: _____

Printed Name: _____

The Builder/Contractor acknowledges that he/she has received, read, and will abide by the Declaration, Design Manual, and the Builders/Contractors Rules & Regulations.

I/We have read this Acknowledgment Statement. Furthermore, I (We) have been given sufficient opportunity to discuss any questions we may have regarding these requirements with a member of the Design Review Panel. My (Our) signatures(s) below is / are evidence of my/our intent to comply with these requirements.

Builder/Contractor Signature: _____ Date: _____

Printed Name: _____

Changes Application - FORM C

Property Information:

Street Address: _____

Owner Information:

Name: _____

Mailing Address: _____

Phone: _____ Email: _____

Architect Information:

Name: _____

Mailing Address: _____

Phone: _____ Email: _____

Builder Information:

Name: _____

Mailing Address: _____

Phone: _____ Email: _____

Landscape Designer Information:

Name: _____

Mailing Address: _____

Phone: _____ Email: _____

Information:

1. Has the requested change or modification already been constructed?

Yes

No

If yes, please explain:

2. Change Description and reason for change:

(Attach specific drawings of proposed change)



Changes Application - FORM C

3. Submit Digital Plans (PDF) to info@starlingcommunity.com
 - Plans/Elevation
 - Details/Samples
4. Submit Review Fee (Checks payable to Starling Community Association, Inc.)
 - \$150 (for proposed modifications) or \$500 (for "after the fact" modifications)

Mail to: Starling Community Association, Inc.
2880 Technology Blvd West
Suite 273
Bozeman, MT 59718

Acknowledgement Statement

The Lot Owner acknowledges that he/she has received and read the Declaration, Design Manual, Rules and Regulations, Bylaws, and other governing documents, and all amendments and supplements thereto ("Governing Documents"). The Governing Documents may also be reviewed at any time at www.starlingcommunity.com. The Lot Owner agrees to abide by the Governing Documents.

As stated in both the Declaration and Design Manual, the failure to strictly comply with the Governing Documents in the construction of any Improvement on the Lot may result in the Board taking action against the Lot Owner, including without limitation assessing substantial fines and requiring the Owner to pay all costs to bring the Lot into compliance.

I/We have read this Acknowledgment Statement. Furthermore, I (We) have been given sufficient opportunity to discuss any questions we may have regarding these requirements with a member of the Design Review Panel. My (Our) signatures(s) below is / are evidence of my/our intent to comply with these requirements.

Owner Signature: _____ Date: _____

Printed Name: _____

The Builder/Contractor acknowledges that he/she has received, read, and will abide by the Declaration, Design Manual, and the Builders/Contractors Rules & Regulations.

I/We have read this Acknowledgment Statement. Furthermore, I (We) have been given sufficient opportunity to discuss any questions we may have regarding these requirements with a member of the Design Review Panel. My (Our) signatures(s) below is / are evidence of my/our intent to comply with these requirements.

Builder/Contractor Signature: _____ Date: _____

Printed Name: _____